



Congratulations on your purchase of a Mountain Tarp flip tarp system. We promise that all our tarp systems are built from the highest quality material available, therefore we can also vow to stand behind our product. No matter how long you search you will not find a better built tarp system than you can get right here in the mountains of Southeastern Kentucky.

WARNING:

- **Never** operate tarp system under power lines, this may cause injury due to electrocution.
- **Never** operate tarp system while moving.

CAUTION:

- Read through instructions for entire system and follow directions thoroughly to ensure the system functions properly.

TOOLS REQUIRED:

- Ratchet
- 3/8", 1/2", 9/16", and 3/4" Sockets and Wrenches
- Pipe Wrench
- Welder– Steel and Aluminum
- Screw Driver
- Drill
- 3/8" and 1/2" Drill Bits
- 1-1/2" Hole Saw
- Snap Clamps

CONTENTS OF MANUAL FLIP TARP SYSTEM:

1— Roller Assembly	2— Hex Cold Roll with Clip (19")	2— Bent Arms
2— Spring Plates	2— End Plates (Optional)	1— Gear Box Assembly
1— Screen Flip Tarp	1— Extruded Face Shield (Optional)	1— Gear Box Crank Handle
4— Flange Bearings (1" Bore)	2— Arm Connectors	1— Piece Sprocket Chain
2— Hex Spring Retainers	1— Crossover (96" or 102")	1— Chain Guard
1— 5/8" Spring (Driver) - Grey Dot	1— Bolt Bag for Flip Tarp Kit	
1— 5/8" Spring (Passenger) - Red Dot	4— Hose Clamps	

Installation Table of Contents

Step 1: Head Roller Assembly	2-3	Step 7: Tarp	8
Step 2: Underbody Assembly	3-4	Step 8: Crossover	8
Step 3: Under the Rail Hex Assembly	4	Operating Instructions	9
Step 4: Clock Spring Underbody Assembly	5	Maintenance	9
Step 5: Gear Box, Chain & Chain Guard	5-6	Wiring Diagrams	10
Step 6: Arms	7	Parts Guide	11

Flip Tarp Dump Body Installation

Step 1: Installing Head Roller Assembly

1A:

Mounting the roller assembly. The roller assembly can be mounted to the cab protector using one of two methods.

- Through the cab protector
- On top of the cab protector using end plates and a wind shield

Choose the method you wish to use and follow the instructions below for that particular method.

1B:

Installing the Motor. Mounting the motor is similar to doing the stub shaft with sprocket. The only difference is the sticker that comes with the motor box. This sticker provides the hole pattern needed for mounting the motor.

1C:

Mounting the roller assembly through the cab protector, see figure 1. To use this mounting method there must be a distance of at least four inches between the top of the rail on the outside of the cab protector and the horizontal shield plate, see figure 1a. If this distance is available and the “through the cab protector” mount is desired, then follow these instructions.

The first step is to choose the proper location on the cab protector to install the assembly (Note: The assembly should be located at a position on the cab protector so that when the system is in the uncovered position the tarp arms do not interfere with either the doors or the loading process). When the proper location is achieved, measure down at that position two inches from the top of the rail on the cab protector and, using a 2” hole saw, cut a hole in the side of the rail on both sides of the cab protector. Next, mount one 3-piece bearing on the outside of the rail on both sides of the dump body by centering the bearing hole with the previously drilled hole in the rail and, using a 3/8” drill bit, drill holes in the rail to match the mounting holes in the bearing. Then, using 5/16” x 1” hex bolts, 5/16” flat washers and 5/16” nuts, mount the bearing firmly to the rail.

Next, place the roller bar inside the cab protector and insert the stub shaft with sprocket welded in through the bearing on the driver side of the body and then into the end of the roller bar. Slide the shaft in so that the sprocket is two to three inches from the outside of the cab protector, see figure 1b, then using a 3/8” drill bit, drill a hole in the roller bar to match the pre-drilled hole in the stub shaft. Then, using 5/16” x 2-1/2” hex bolts, 5/16” flat washers and 5/16” nuts provided, fasten the shaft to the roller bar. Repeat this step on the other side using the stub shaft only provided.

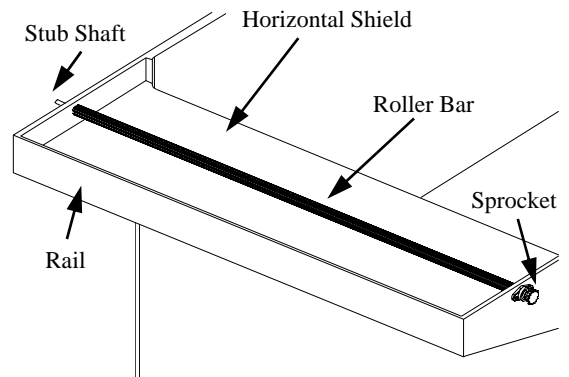

Figure 1

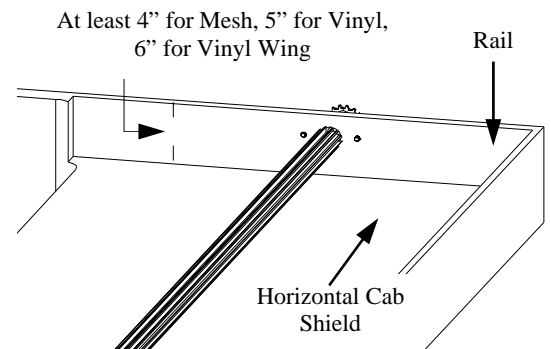

Figure 1a

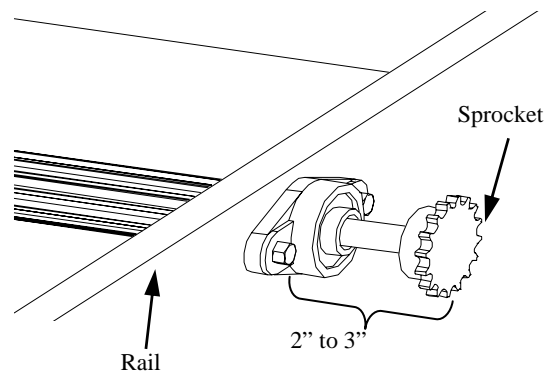

Figure 1b

Flip Tarp Dump Body Installation

Step 1: Installing Head Roller Assembly Cont.

1D:

Mounting the roller assembly on top of the cab protector, see figure 2. The first step is to choose the proper location on the cab protector to install the assembly (Note: The assembly should be located at a position on the cab protector so that when the system is in the uncovered position the tarp arms do not interfere with either the doors or the loading process). When the proper location is achieved the next step is to mount the end plates.

With the center of the end plate at the previously determined position, hold the end plate so that the bottom is 2-1/2" below the top of the rail on the cab protector, see figure 2a. Then, using a 1/2" drill bit, drill two holes near the bottom of the end plate, through the end plate and the rail. Then using 1/2" x 1-1/2" hex bolts, 1/2" flat washers and 1/2" nuts, mount the end plate firmly to the cab protector. Repeat this on the other side of the body.

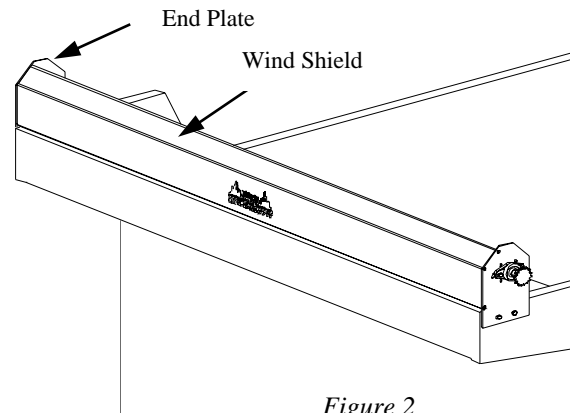

Figure 2

The next step is to install the wind shield. First, measure from the inside of one end plate to the inside of the other and if necessary cut the wind shield to this length. Next, place the shield so that the mounting slots at the end match up with the holes in the end plates. Then, using the 3/8" machine bolts provided, fasten the shield to the end plates. After the wind shield is installed, the next step is to mount the roller bar assembly. The first step is to mount the flange bearings on the outside of each end plate. Using, 5/16" x 1" hex bolts, 5/16" flat washers and 5/16" nuts, mount the bearings to the plates using the pre-drilled holes. Next, place the roller bar between the end plates and insert the stub shaft with sprocket welded through the bearing on the driver side and into the end of the roller bar. Slide the shaft in so that the sprocket is two to three inches from the outside of the end plate, see figure 1b, and then using a 5/16" drill bit drill a hole in the roller bar to match the pre-drilled hole in the stub shaft and connect them using 5/16" by 2-1/2" hex bolts, 5/16" flat washers and 5/16" nuts. Repeat this for the opposite side of the body using the stub shaft only provided.

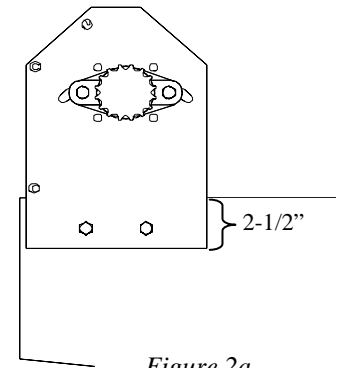

Figure 2a

Step 2: Installing Underbody Assembly

2A:

Finding the placement for the underbody assembly (pivot point). See Figure 3. To find the placement for the underbody assembly you must find the center point of the dump body. Using two tape measures, hook the end of one to the tarp axle and the end of the other to the very top rear corner of the tailgate and measure toward the center at the bottom of the body. At the distance where the tape measures cross reading the same measurement is the center point of the system (Note: the pivot point must be at least 3-1/2" from nearest horizontal standard, adjust forward to fall short of tailgate, adjust rearward to fall short of roller box), see figure 3a. Then using a one and one half inch hole saw, cut a hole in the bottom rail. This is the pivot point of the system.

For height of pivot point, add 1-1/2" to this measurement. Example: If the distance from the bottom of the bottom rail to the bottom of the horizontal standard is 1/4", the pivot point will be 1-3/4" from the bottom of bottom rail.

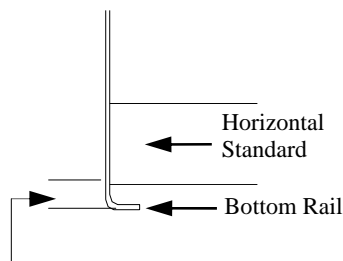

Figure 3a

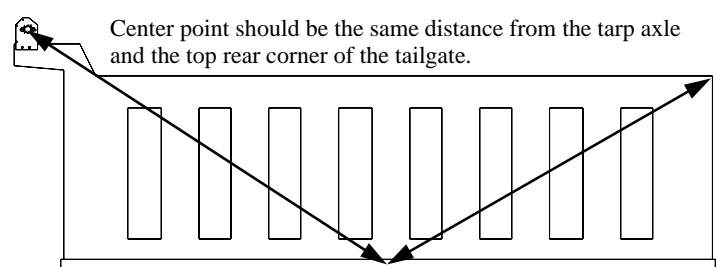

Figure 3

Flip Tarp Dump Body Installation

Step 2: Installing Underbody Assembly Cont.

2B:

Installing the spring assembly, see figure 4. After cutting the hole for the pivot point the next step is to install the spring assembly. First place the assembly inside the bottom rail with the shaft protruding out through the previously cut hole. Then, slide the flange bearing onto the end of the spring shaft and center the bore hole in the bearing with the previously cut hole in the bottom rail of the trailer.

Next, using a 3/8" drill bit, drill holes in the bottom rail to match the bolt holes in the bearing. Then, using 3/8" x 2" hex bolts, 3/8" flat washers, and 3/8" nuts, fasten the bearing firmly to the bottom rail of the trailer (Note: when inserting bolts, hold the spring retainer against the inside of the rail and put the bolt through the bearing, the rail and the spring retainer before placing the washer and nut. The retaining wings on the spring retainer should be on top).

With the flange bearing in place, the next step is to secure the bearing to the spring shaft by tightening the allen screws on the bearing. Before you do this make sure that the spring is pulled firmly against the spring retainer and the clip on the spring shaft is centered in the "U" shaped portion of the spring. Then, tighten the allen screws firmly.

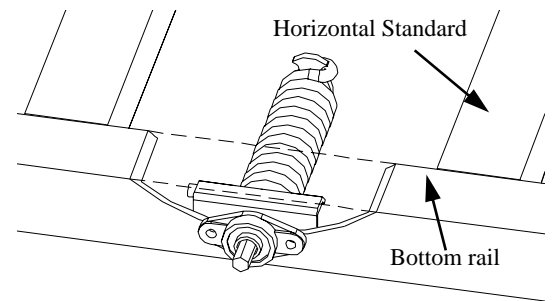

Cut-away assembly view,
do not cut bottom rail!!

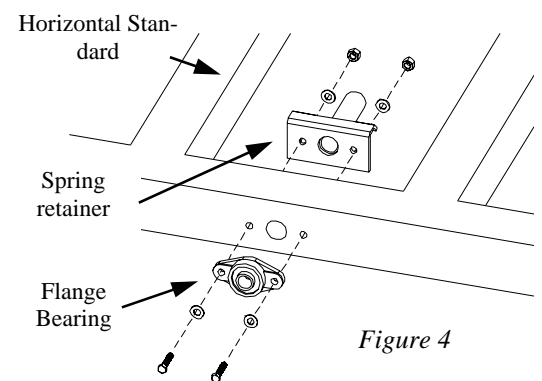

Step 3: Installing Under the Rail Hex Assembly

3A:

Assembling the spring, shaft, spring retainer, and spring plate, see figure 4b.

3B:

Installing the spring and shaft assembly, see figure 4c. Hold previously assembled spring and shaft under the body so that the top of the spring retainer is against the bottom of the bottom rail and the spring plate is on the outside of the bottom rail. Using a 3/8" drill bit, drill holes in bottom rail to match holes in spring plate. Next using 3/8" x 2" hex bolts, 3/8" flat washers, and 3/8" nuts, fasten assembly to bottom rail

(Note: if spring and shaft assembly interferes with obstructions under the body, it may be necessary to dismantle spring plate and mount through the rail. See *Instructions for Installing Underbody Assembly*. Follow the instructions on page 4, except the pillow block bearing and angle will not be needed).

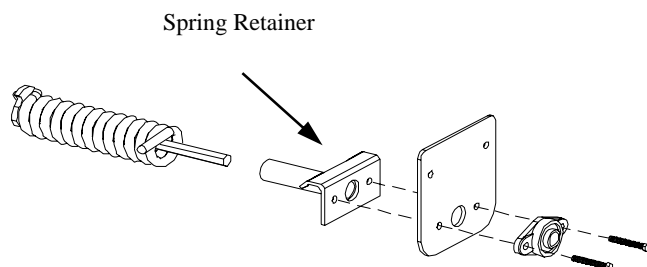

Figure 4b

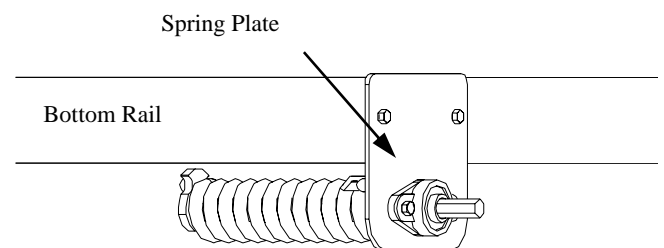

Figure 4c

Flip Tarp Dump Body Installation

Step 4: Installing Clock Spring Underbody Assembly

4A:

Installing the optional clock spring assembly, see figure 3 for establishing pivot point. After marking the pivot point place the pivot pin as shown in figure 4b and mark holes to be drilled, once holes have been marked, drill 1/2" holes and bolt pivot to body using the supplied bolts, (or weld) insuring that the spring notch is pointed down.

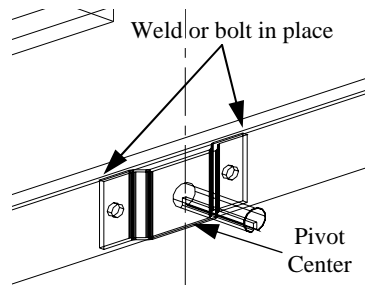

Figure 4b

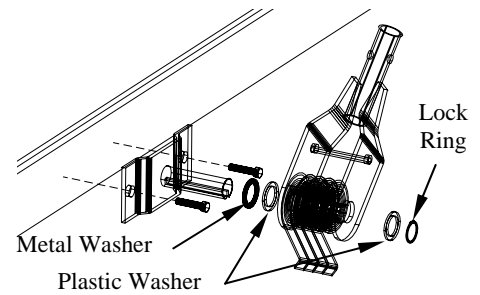

Figure 4c

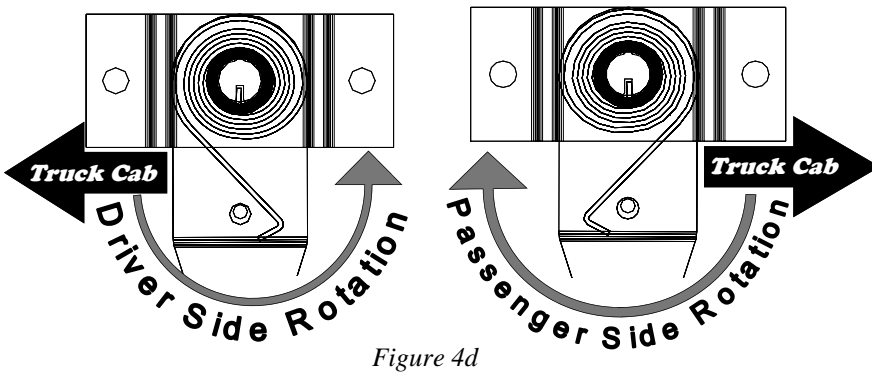

Figure 4d

4B:

Install the spring assembly connector as shown. See figure 4c (Note: Pivots are directional, rotate pivots so that the spring hooks will clip over the inside pin as shown in figure 4d).

Step 5: Installing Gear Box, Chain & Chain Guard (Manual Option Only)

5A:

Installing the gear box assembly. The gear box should be installed at the very front of the bottom rail on the driver side, unless a passenger side mount is preferred. First, find the most convenient place, as close to the front of the body as possible, (Note: It may be necessary to fabricate a mount if no flush mount fender is available) and clamp the gear box in place (Note: It may be necessary to angle the gear box so that its top is pointing directly at the sprocket on the end of the head roller assembly).

When the proper placement and angle is achieved, lower the gear box until the bottom of the box is resting on the bottom rail or applicable mounting structure, then using a 3/8" drill bit, drill holes in the rail at the very top of the slots in the flange at the bottom of the gear box, see figure 6. These slots will allow you to adjust the gear box to either change the angle or to tighten the chain once installation is complete. After drilling the holes, using 3/8" x 1-1/2" hex bolts, 3/8" flat washers, and 3/8" nuts, secure the gear box to the rail, but do not tighten completely.

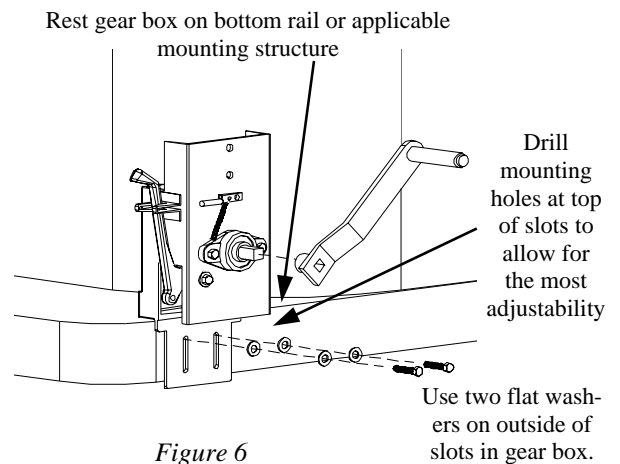
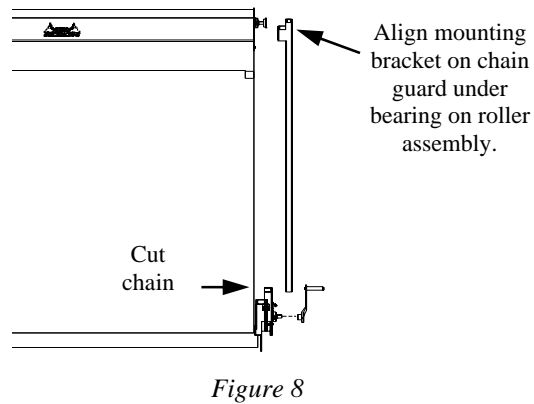
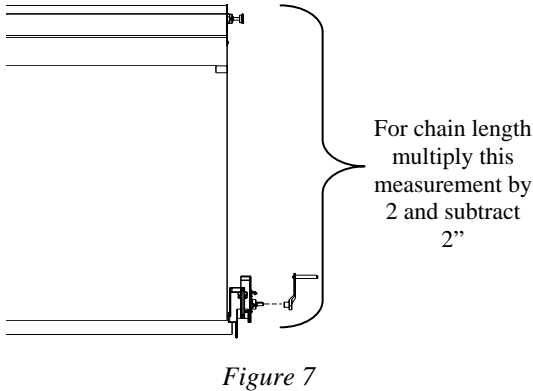

Figure 6

Flip Tarp Dump Body Installation

Step 5: Installing Gear Box, Chain & Chain Guard Cont. (Manual Option Only)

5B:
Installing the sprocket chain. To find the chain length, first slide the gear box up so that the mounting bolts are at the bottom of the slots in the mounting bracket. Next, measure from the top of the sprocket on the roller box assembly to the bottom of the gear box, double this measurement and subtract two inches, *see figure 7*. Using the proper cutting tools, cut the chain at this length, wrap the chain around the sprocket on the gear box and the sprocket on the head roller box and connect the ends using the master link provided (Note: if necessary, loosen bolts connecting the gear box to the bottom rail and adjust to create or eliminate slack, then retighten bolts).



5C:
Installing the chain guard (T). After installing the chain, you need to connect the chain guard to the gear box and the head roller assembly (Note: In order to install the chain guard with the chain already in place, you need to cut a slot in the mounting bracket on back of the chain guard. If this is not preferred, you will need to remove the chain, install the chain guard and then replace the chain, *see figure 8b*). The first step is to find the proper length for the chain guard. This is achieved by simply measuring from the bottom of the bearing on the outside of the head roller assembly to the top of the metal plate on the back of the gear box, *see figure 8*.

After the guard has been cut to the proper length, using a 3/8" drill bit, drill two holes through the chain guard to match the holes on the gear box. Then, drill two 3/8" holes through the mounting plate on the rear of the chain guard and the end plate on the head roller box, *see figure 8a*. After drilling the holes, using 3/8" x 1" carriage bolts, 3/8" flat washers, 3/8" lock washers, and 3/8" nuts fasten the chain guard to the gear box and using 3/8" x 1-1/4" carriage bolts, 3/8" flat washers, 3/8" lock washers, and 3/8" nuts, fasten the chain guard to the head roller box. When the gear box, chain guard, and head roller box are firmly connected and in the desired position, then firmly tighten the bolts mounting the gear box to the bottom rail.

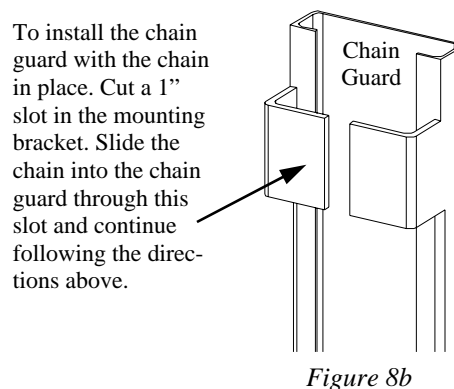
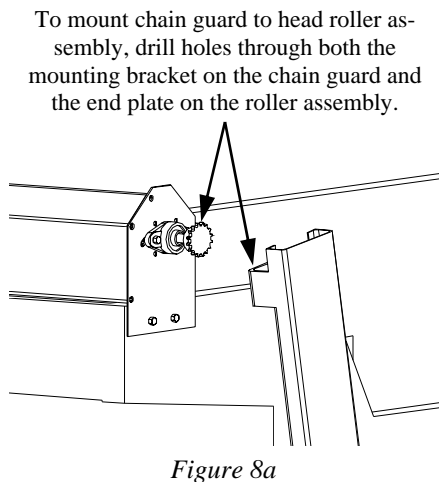

Flip Tarp Dump Body Installation

Step 6: Connecting the Arms

6A:

Connecting the arms (P) to the spring shaft. Before connecting the arms you must first determine the length they need to be. To do this, measure from the center of the spring shaft to the rear of the tailgate and subtract 4". This will allow for the legs on the crossover and the arm connector (Note: this method of measurement is used if the pivot point of the system is at or less than seven inches from the center of the dump body. If this measurement is greater than seven inches then measure from the center of the spring shaft to the center of the tarp axle on the roller assembly and subtract 4". This will cause the system to fall just short of the rear of the tailgate), see figure 9. When the proper length is achieved, cut the arms and scrap the remaining material.

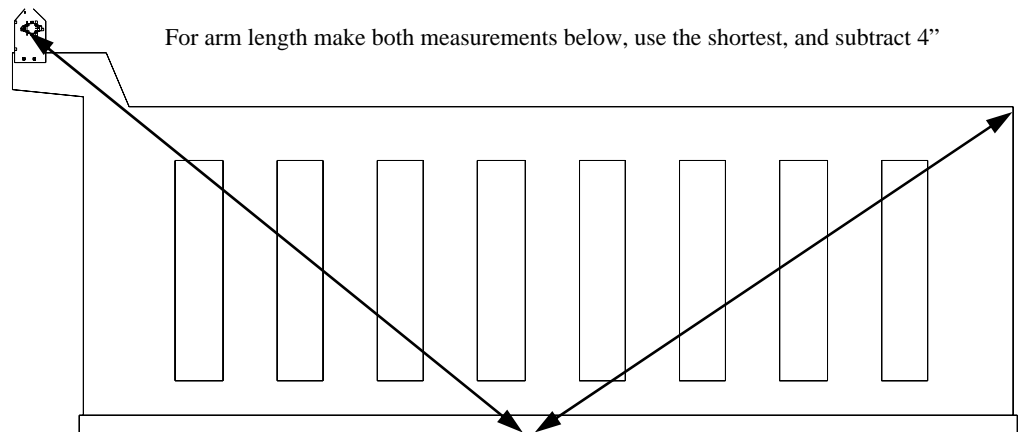

Figure 9

Note: Set arm connectors at five o'clock before attaching arms on both sides.

After the arms are cut, the next step is to connect them to the spring shaft, see figure 9a. First slide the arm connector (L) onto the shaft and slide the arm onto the pipe on the arm connector (Note: the arm and connector should be pointing toward the rear of the dump body with the end of the arms resting on the ground). Slide the arm until it is against the plug on the connector, then, using a 3/8" drill bit, drill a hole through the arm and the pipe on the connector and fasten using a 3/8" x 2-1/2" hex Bolt, 3/8" flat washers, and a 3/8" nut. After bolting the arm to the arm connector, the next step is to get the proper spacing between the arms and the body.

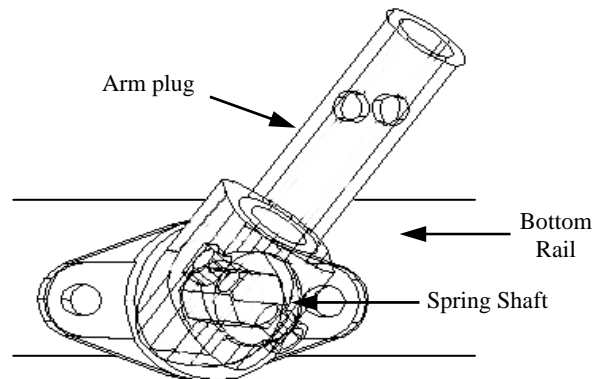

Figure 9a

With the end of the arms resting on the ground, adjust them so that there is one inch between the arm connector and the flange bearing on the spring and shaft assembly and six inches between the arms and the tires on the truck, see figure 9b. Then, make sure the cold roll (spring shaft) is turned until the cold roll clip is against the inside of the "U" shaped bend in the spring, then, placing a pipe wrench between the arm connector and the flange bearing, turn the spring shaft toward the front of the trailer one to five hours to put tension on the spring. With the shaft held at this position, weld the arm connector to the spring shaft (Note: when putting tension on the springs use the following formula: bodies up to 28' - turn one hour, bodies from 29' to 34' - turn 3 hours, bodies from 35' to 37' - turn 5 hours).

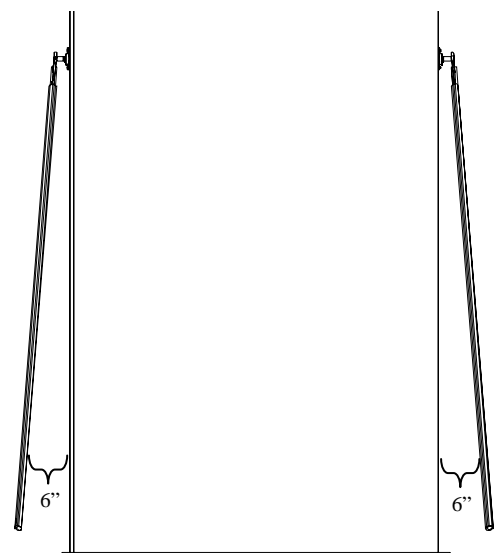

Figure 9b

Flip Tarp Dump Body Installation

Step 7: Installing the Tarp

7A:
Connecting the tarp to the tarp axle, See Figure 10. Attach the tarp to the roller bar with the 3/8" x 3/4" hex bolts and washers provided as shown in figure 10.

7B:
Connecting the tarp to the crossover. To attach the tarp to the crossover simply thread the crossover through the pocket at the end of the tarp, (Note: It may be helpful to spray a lubricating oil into the pocket on the tarp before threading). Then, using the two hose clamps provided, secure the tarp to the crossover. (Notes: The outside edge of the tarp should be 12" from the outside of the crossover, see figure 10a. You will need to cut small slits in the pocket of the tarp to get the hose clamps around the crossover).

Note: When bolting the tarp to the roller bar, the end bolts on each side should be 5" from the end of the roller bar. The remaining bolts should be spaced evenly across the roller bar.

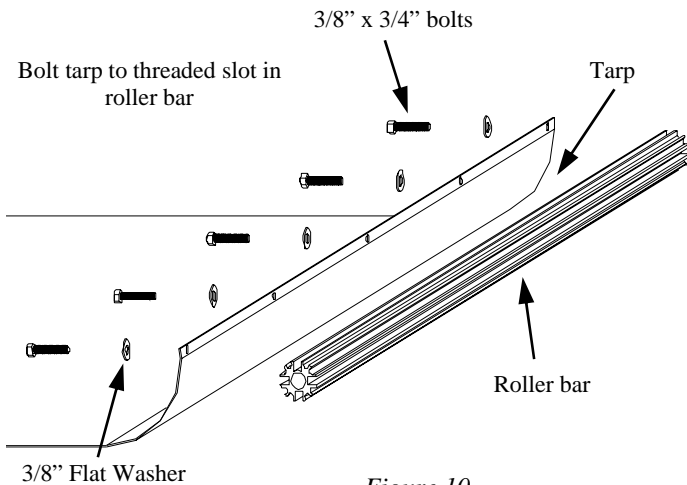

Figure 10

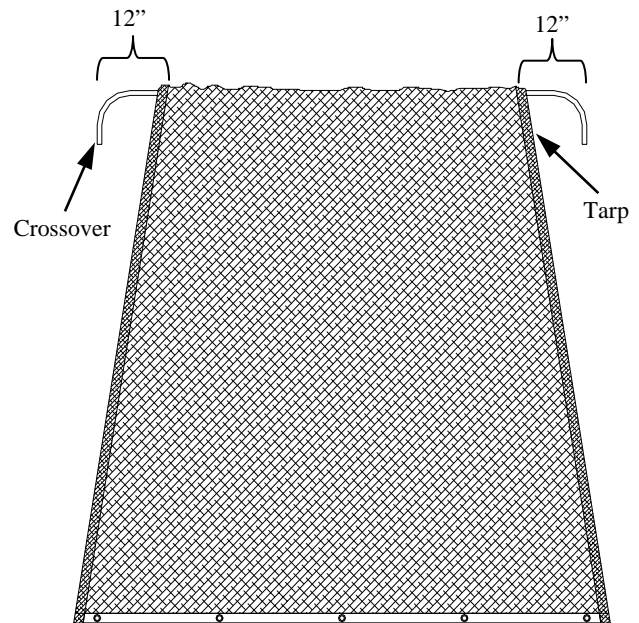

Figure 10a

Step 8: Installing the Crossover

8A:
Connecting the crossover to the arms. Using a ladder, lift the arms up to the top of the tailgate, with the tarp attached, slide the legs of the crossover into the end of the arm on each side of the trailer. Using a 3/8" drill bit, drill a hole through the arm and crossover leg. Using 3/8" x 2-1/2" hex bolts, 3/8" flat washers, and 3/8" nuts, secure the crossover to the arm.

8B:
Repeat steps for the opposite side of the trailer.

Flip Tarp Dump Body Operating Instructions

Operating Instructions for the Flip Tarp System

Covering the load:

1. Turn the crank handle counter clockwise just enough to relieve the pressure on the locking mechanism.
2. With brake applied, turn the clicker handle to 12 o'clock.
3. **REMOVE THE CRANK HANDLE.**
4. Open the gate latch to release the brake handle.
5. Gently release the brake.

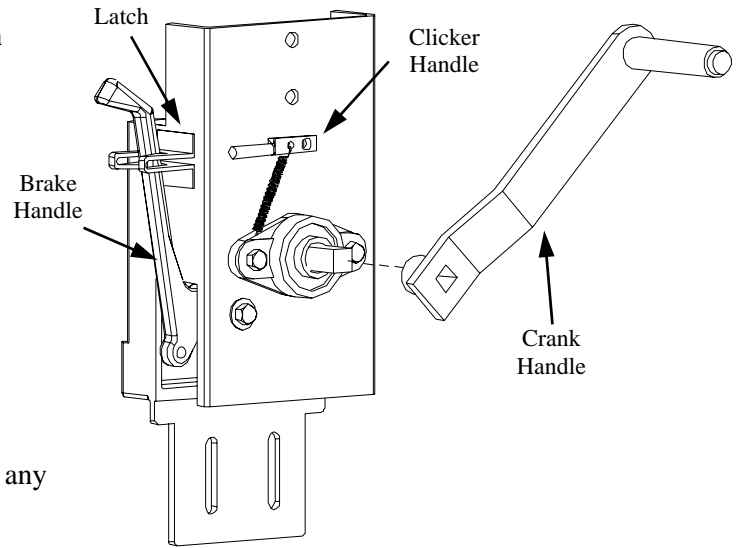

Gear Box

The tarp should begin to flip. You can stop the system at any time by simply applying the brake.

Uncovering the load:

1. Open the gate latch to release the brake handle.
2. Attach the crank handle to the gear box.
3. Turn counter clockwise.

This will roll the tarp up. You can stop at any time and the locking mechanism will hold the system in place. Stop cranking when the tarp is completely rolled up.

Warning: Do not release brake without **REMOVING THE CRANK HANDLE**. Do not release handle unless ratchet pawl is properly engaged. Do not disengage ratchet pawl unless tension is applied to handle. Failure to observe these warnings will cause handle to turn out of control and could cause personal injury.

Flip Tarp System Maintenance

- Spray all bearings and sprocket chain with penetrating oil “NO GREASE”.
- Brush spring with steel brush weekly to remove dirt and spray with penetrating oil.

Flip Tarp Dump Body Wiring Diagrams

Wiring Diagram for Electric Option

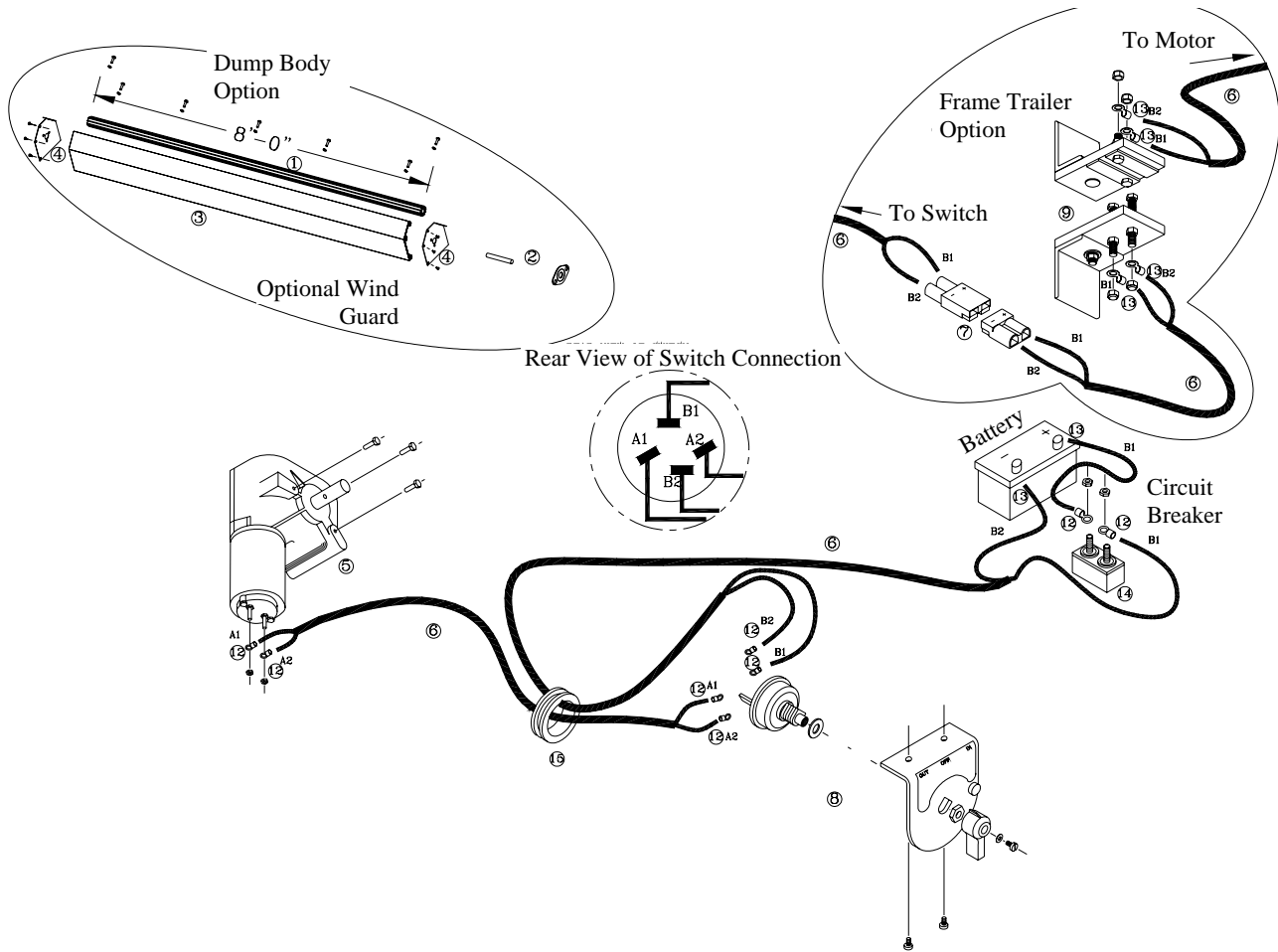

NEW Wiring Diagram for Rocker Switch

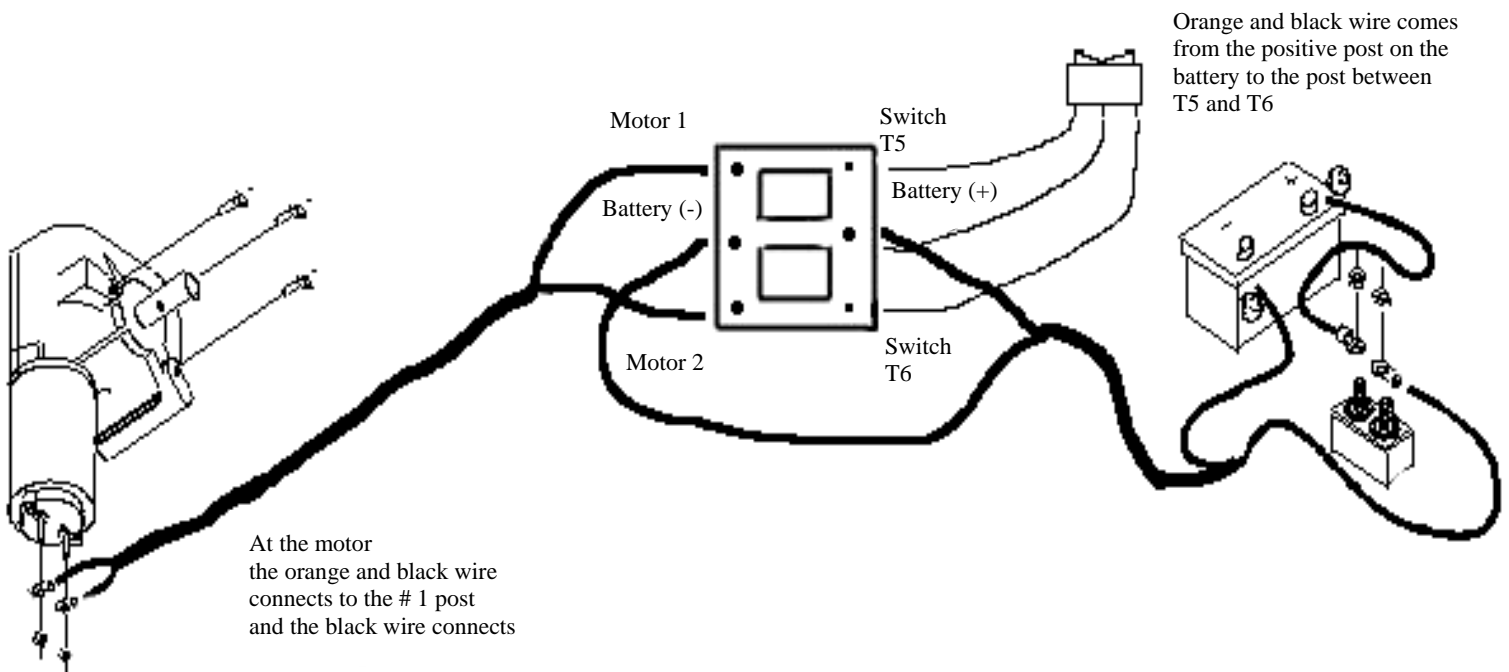

Parts for Manual Flip Tarp Dump Body

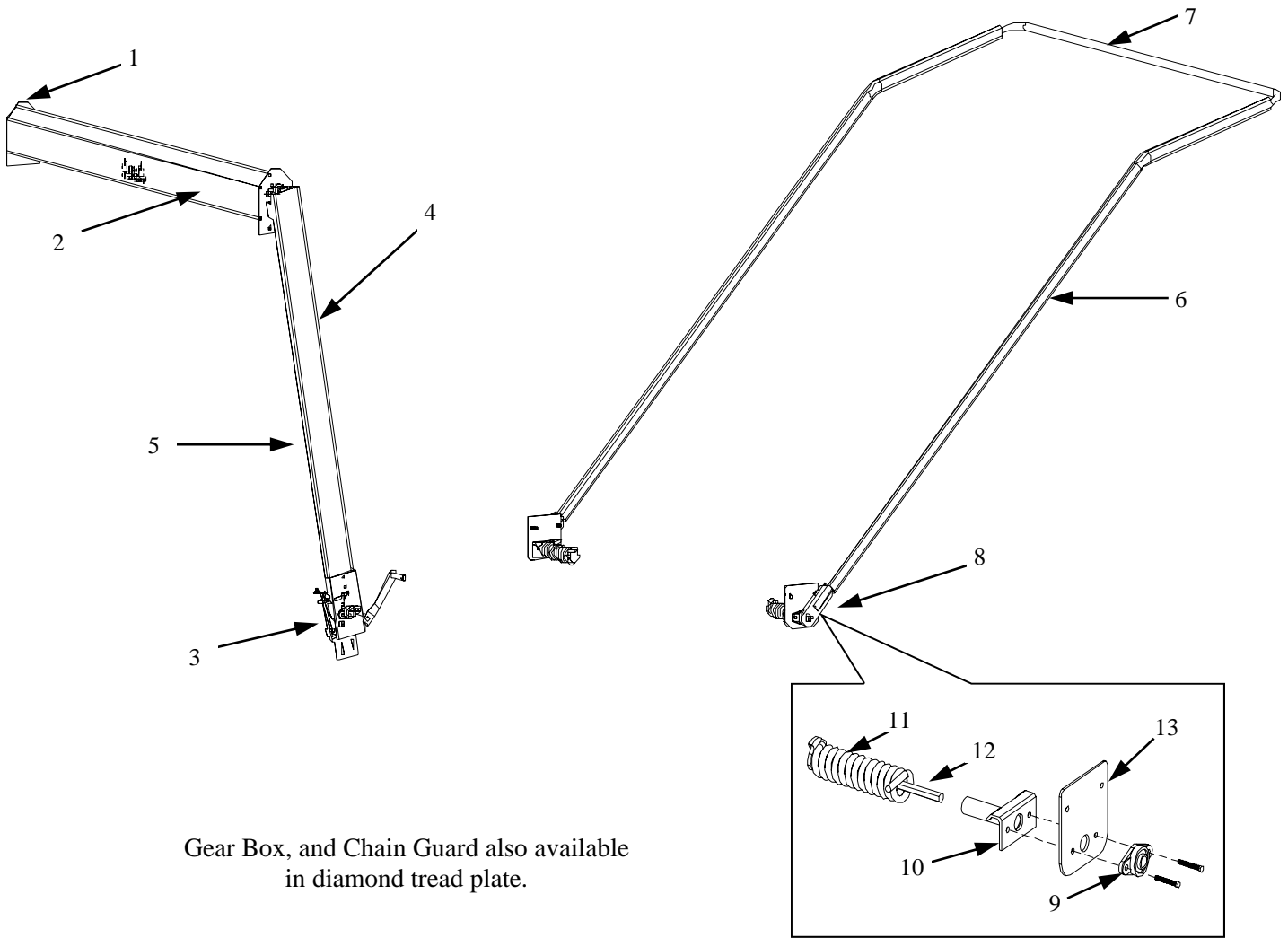

Gear Box, and Chain Guard also available in diamond tread plate.

Des. #	Description	Part #	Des. #	Description	Part #
1	End Plate (Driver Side)-Optional	K0117	7	Crossover (102")	K0422
1	End Plate (Passenger Side)-Optional	K0118	8	Hex Arm Connector	K0416
2	Wind Shield-(Optional)	K0109	9	Flange Bearing	K0515
3	Gear Box Assembly	KS6340	10	Hex Spring Retainer	K0193
4	Chain Guard	K0201	11	Spring (Driver Side)	K0501
5	Sprocket Chain (16' Piece)	K0220	11	Spring (Passenger Side)	K0502
6	16' Bent Arm	K0411B	12	Hex Cold Roll With Clip 19"	K0522C
7	Crossover (96")	K0420	13	Spring Plate	K0192